

About Us

We appreciate your business!

Congratulations on your new SAWYER product. We are proud to have you as our customer and will strive to provide you with the best service and reliability in the industry. This product is backed by our extensive warranty and world-wide service network. To locate your nearest distributor or service agency, please contact us at the phone number and address listed on the bottom of each page.

You are in good company!

Sawyer Manufacturing Company is the world leader in the design and manufacture of pipeline and welding equipment and has been since 1948. Sawyer equipment has become a standard in the industry and continues to set the benchmark for quality and durability.

This user operation manual has been made to instruct you for the best use and operation of your Sawyer product. Your satisfaction with our products is our main goal. Please read this entire manual carefully, noting all tips, notes and warnings. Safety always comes first.



Large Internal Clamp Manual

Models 241 & 245

Parts Diagram

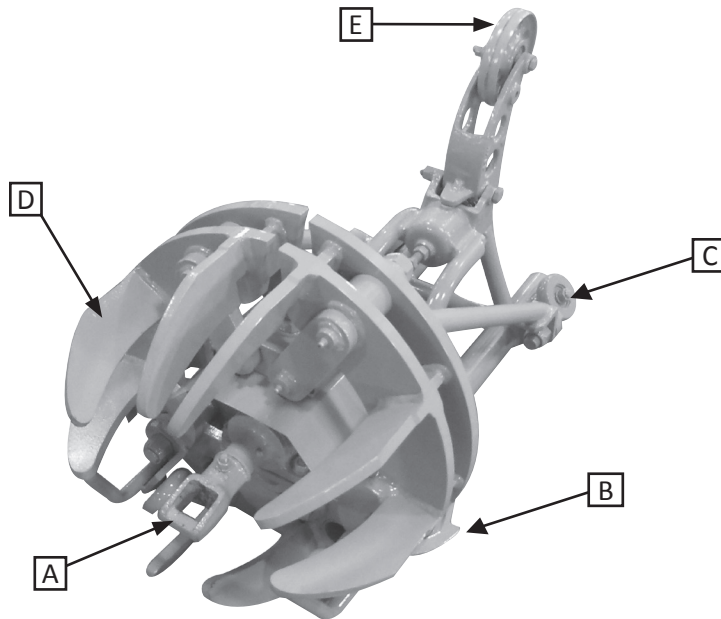

- A. Input Shaft Eye
- B. Stop
- C. Guide Wheels
- D. Pipe Rests
- E. Tail Wheel

F. Hook **not pictured**

G. Reach Rod **not pictured**

H. Crank Handle **not pictured**

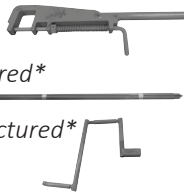

CAUTION



CAUTION: Sawyer Manufacturing offers an easy to use line of internal line up clamps for the purpose of welding two pipes together. The internal line up clamps are not intended to be used as sole supports of the pipe nor to lift the pipe. After each use clean and store in a warm, dry area.

Record the following information for warranty purposes:

Where purchased: _____

Purchase date: _____

Equipment Serial #: _____

Warranty

All products manufactured by or for Sawyer Manufacturing Company are guaranteed against defects due to faulty workmanship or materials for twelve months from the date of purchase.

This guarantee is limited to the repair or replacement of any parts found to be defective, and no other liability—expressed, implied, or contingent—is assumed.

Installation

Tools Needed For Operation/Cutting*



*Not Included

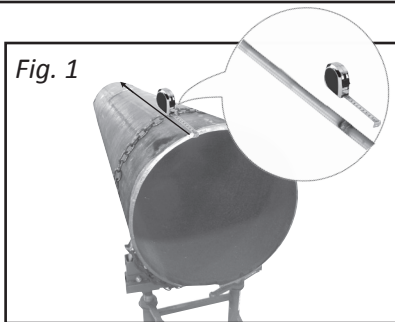

1. To find appropriate length of reach rod (G), measure pipe joint to be welded. (Fig. 1)
*Note: Reach rod comes in 7ft sticks
Pipe joint sizes: 40ft weld 7 rods,
60ft weld 10 rods,
80ft weld 13 rods*

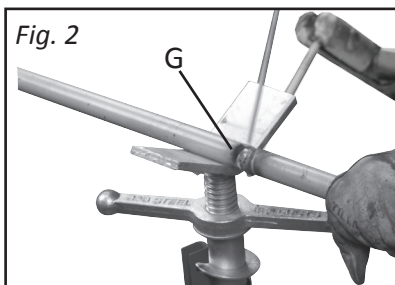

2. Weld needed reach rod (G) together. (Fig. 2)

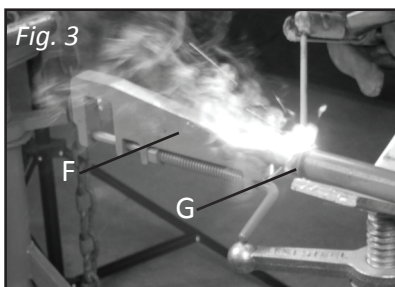

3. Weld end of reach rod (G) to end of hook. (F, Fig. 3)

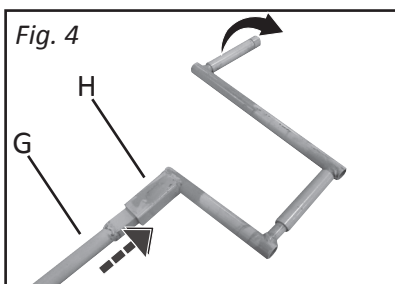

4. Insert square end of reach rod (G) into square end of crank handle. (H, Fig. 4)

Operation

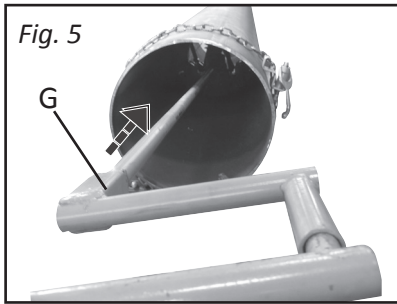

1. Insert reach rod (G) through pipe joint to be welded. (Fig. 5)

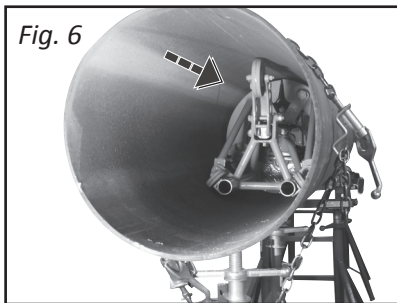

2. Place clamp into pipe joint. (Fig. 6)

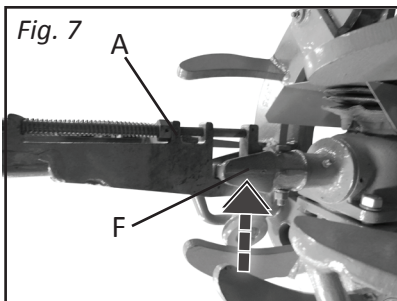

3. Clip hook (F) onto input shaft eye. (A, Fig. 7)

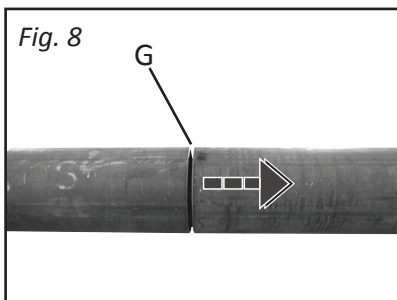

4. Move secondary pipe joint into place, while reach rod (G,) travels through the secondary pipe. (Fig. 8)

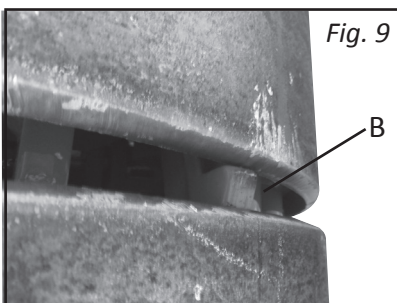

5. Pull clamp through pipe joint until stops (B) catch. (Fig. 9)

Operation

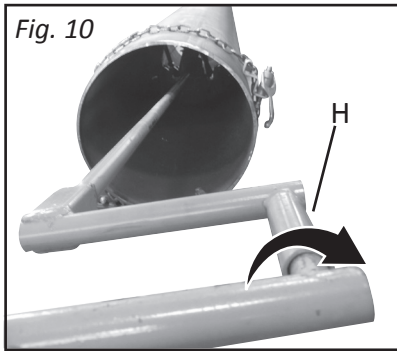

- 6.** Turn crank handle (*H*) clockwise until clamp is fully expanded inside pipes. (*Fig. 10*)

Note: Clockwise = tighten, counterclockwise = loosen

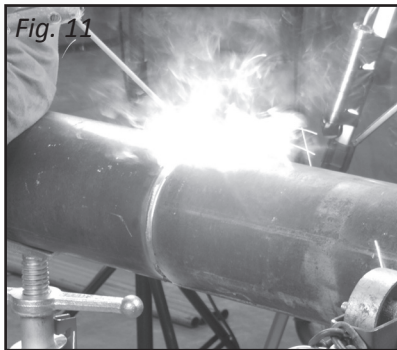

- 7.** Weld pipes together. (*Fig. 11*)

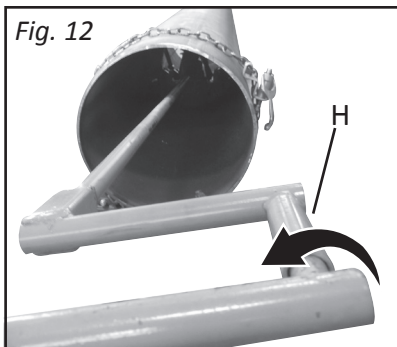

- 8.** Turn crank handle (*H*) counterclockwise until clamp is full released. (*Fig. 12*)

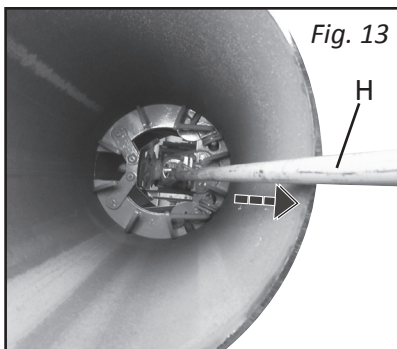

- 9.** Pull clamp through secondary pipe. (*Fig. 13*)