

Hi-T Pigalert™

INSTALLATION, OPERATION AND MAINTENANCE MANUAL

REVISION: 07/2013

READ AND UNDERSTAND THIS MANUAL PRIOR TO OPERATING OR SERVICING THIS PRODUCT.

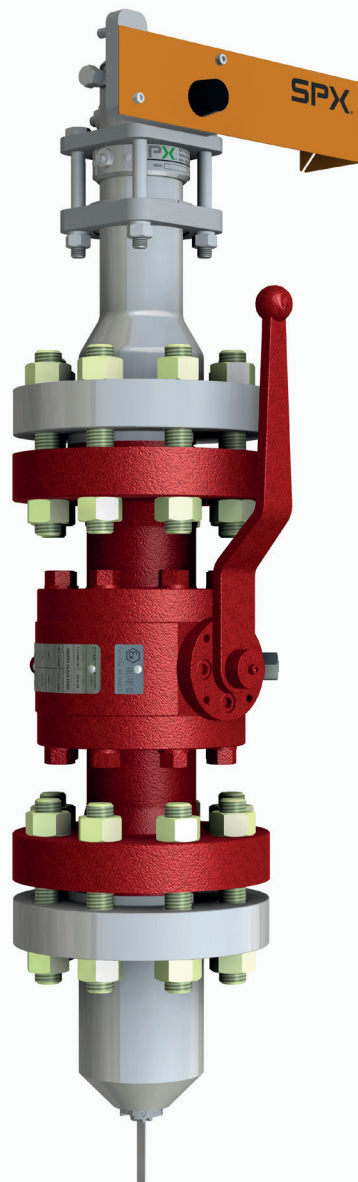

CONTENTS

HI-T PIGALERT:

- 1.0 Standard Model
- 2.0 Procedure for fitting Welded Base Models
- 3.0 Adjustment - All Models
- 4.0 Installation (Non Valved Models)
- 5.0 Installation (Centre Section Ball Valved Models)
- 6.0 Installation (Flanged Ball Valve Models)
- 7.0 Maintenance
- 8.0 Maintenance - General
- 9.0 Extension Models
- 10.0 Setting Details - All Models
- 11.0 Models with a Counter

Each Signaller is specifically designed to provide safe operation at the pressure/temperature rating shown on the name plate and to comply with the design conditions stated in the purchase order.

It is the responsibility of the end user to consider the effect of any other external loading conditions that might be applied to the signaller.

1.0 STANDARD MODEL

- 1.1 All Pigalerts incorporate standard body and internal details. Variations are obtained by selecting from the listed options (see product literature).
- 1.2 All Pigalerts are designed for operation through a minimum hole diameter of 39mm.
- 1.3 Welded bases are supplied with an allowance for a 3mm root gap.
- 1.4 All models can now be set to suit varying thicknesses of line pipe of any diameter of 8" and above without being limited to pre-set lengths of mounting bases. The trigger carrier mechanism can be extended or retracted into the main body by simply releasing a locking screw to achieve the correct length. The maximum adjustment is 25mm (1.0 inch).
- 1.5 This function can be performed easily on site although customers may prefer to provide details so that pre-setting can be carried out at our works.
- 1.6 Standard units are made in two classifications - up to and including ANSI Class 900 and for ANSI Class 1500 duty. Temperature range is from minus 40°C to plus 100°C, dependent upon pressure and product.

MATERIALS

- 1.7 Standard bases are produced in carbon manganese steel, equivalent to BS:1503-224-490 treated with rust preventative to facilitate cleaning prior to welding.
- 1.8 Pressure housings and internal moving parts together with their associated housings are manufactured from stainless steel to BS:316 S16 or the equivalent cast material.

See Drawing and Data Sheet for specific information.

MAINTENANCE

- 1.9 Under pressure removal/insertion (ball valve model only).
Special Jacking Bracket tool is required.

To carry out this requirement it is necessary to remove the attachments, i.e. flag and switch.

SAFETY WARNING:

Ensure that all nuts and bolts are tight on installation of the HI-T Pigalert

2.0 PROCEDURE FOR FITTING WELDED BASE MODELS

NON-VALVED PIGALERT (e.g. MW, EW etc.)

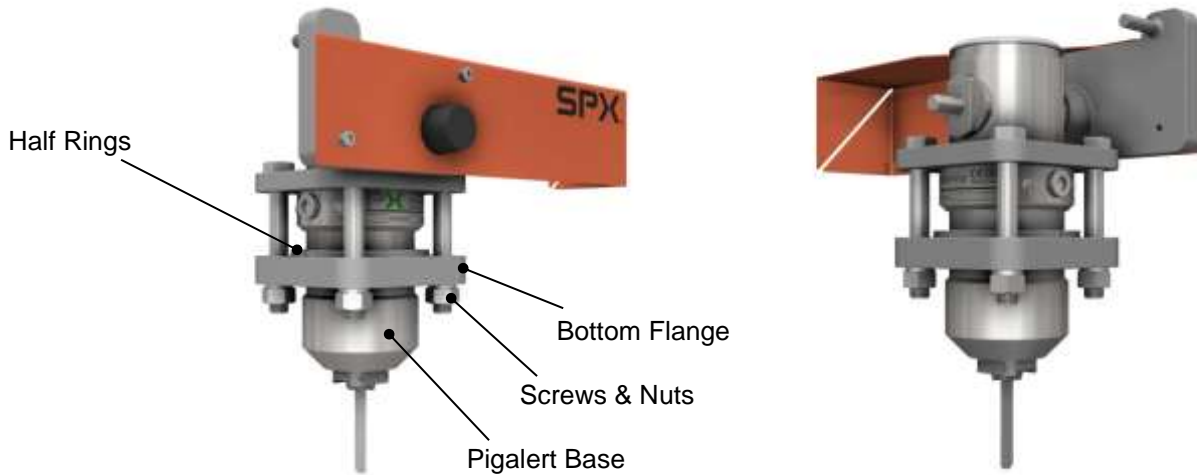

Produce a 39mm diameter hole in top of pipe line.

On the non-valved Pigalert remove base from the assembly by undoing the 4 off M12 x 90 long screws and nuts removing the bottom flange and two half rings - store safely. Clean off the factory applied protection finish from weld profile.

Weld base to pipe line, with a 3mm root gap, ensure that face is set square to the line pipe.

Leave to cool. If a long period before assembly is anticipated smear top face with rust preventative and attach a temporary cover to prevent ingress of dirt.

Check dimension from inside of pipeline wall to top of base. This dimension should be 1.0 to 2.0mm greater than the length of the trigger carrier protruding from the body.

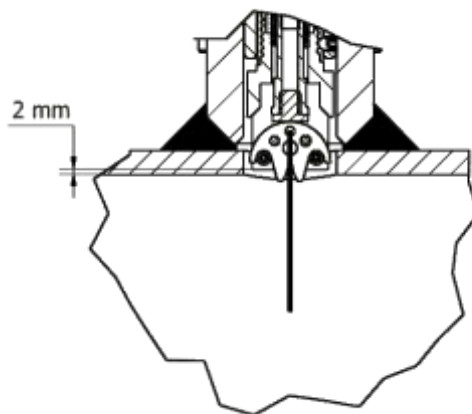

CENTRE SECTION BALL VALVED PIGALERT e.g. VMW, VEW etc.

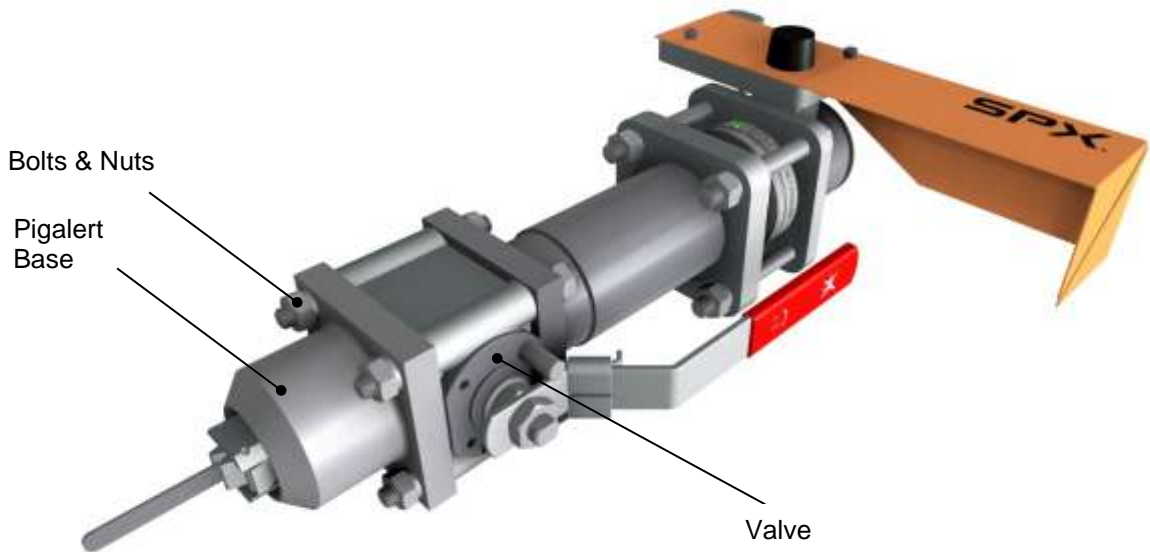

Produce a 39mm diameter hole in top of pipe line.

On the centre section ball valve Pigalert remove the valve from the base by undoing the 4 off M10 x 100 long stud bolts and nuts, take care to ensure the ball valve seal is not lost - store safely. Clean off the factory applied protection finish from weld profile.

Weld base to pipe line, with root gap, ensure that face is set square to the line pipe and the bolt holes are parallel to the centre line of the pipe.

Leave to cool. If a long period before assembly is anticipated smear top face with rust preventative.

Check dimension from inside of pipeline wall to top of base. This dimension should be 1.0 to 2.0mm greater than the length of the trigger carrier protruding from the body.

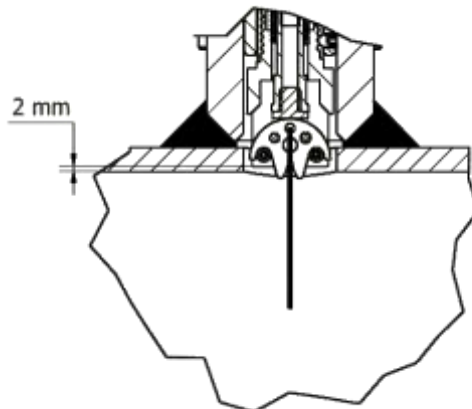

FLANGED BALL VALVE PIGALERT e.g. VMW, VEW etc.

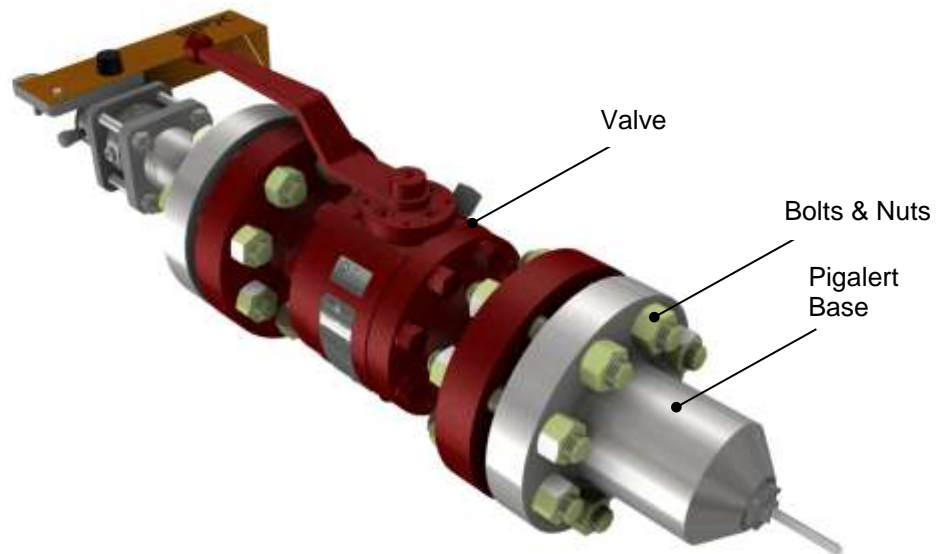

Produce a 39mm diameter hole in top of pipe line.

On the flanged ball valve Pigalert remove the valve from the base by undoing the stud bolts and nuts, take care to ensure the ball valve seal is not lost - store safely. Clean off the factory applied protection finish from weld profile.

Weld base to pipe line, with root gap, ensuring that the valve mounting holes straddle the pipe axis equally.

Leave to cool. If a long period before assembly is anticipated smear top face with rust preventative.

Check dimension from inside of pipeline wall to top of base. This dimension should be 1.0 to 2.0mm greater than the length of the trigger carrier protruding from the body.

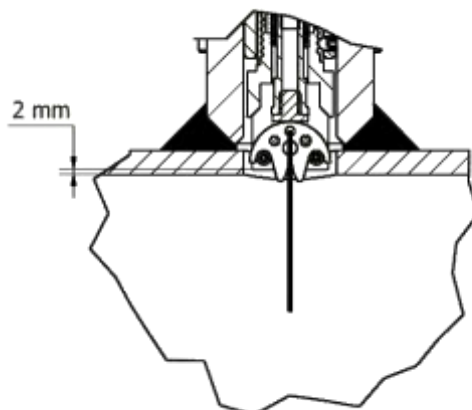

3.0 ADJUSTMENT - ALL MODELS

All Pigalerts incorporate a 25mm range adjustment. To adjust the protrusion length, release the 6mm set screw sufficient to free the trigger carrier. The extension can be adjusted to the desired length by turning in either direction. Rotation must be in increments of 180 degrees to ensure that the two diametrically positioned locking grooves mate with the 6mm set screw.

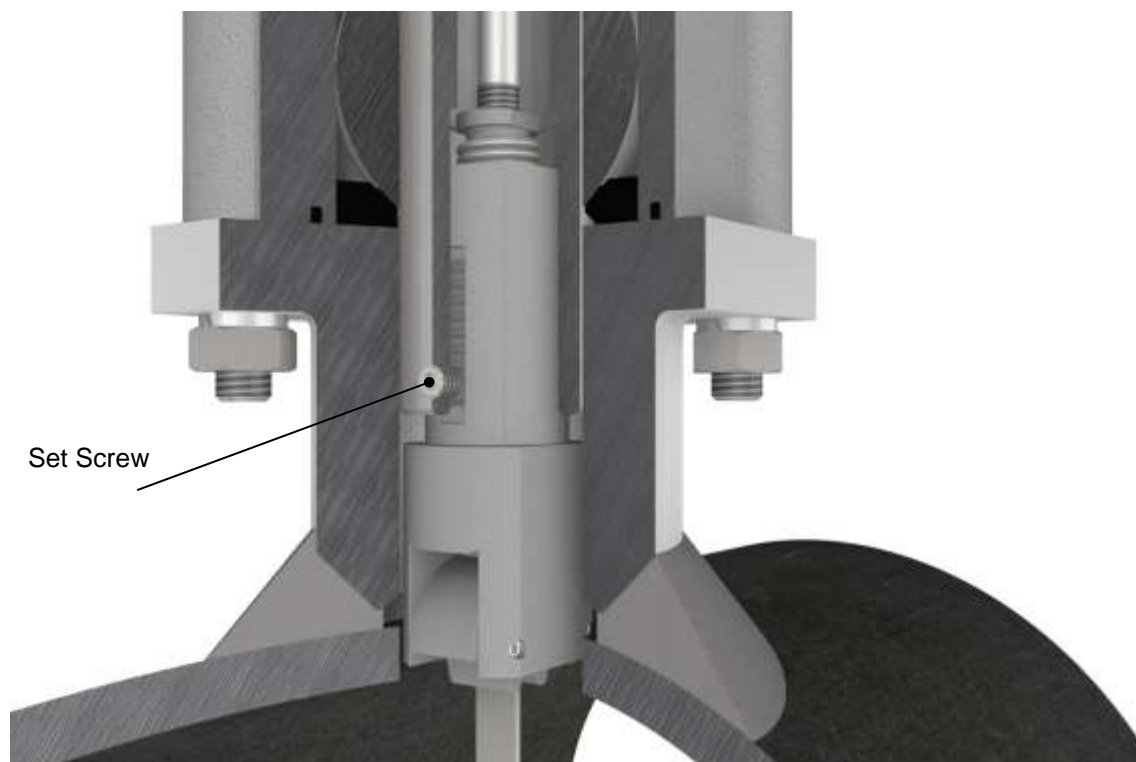

4.0 INSTALLATION - (NON VALVED MODELS e.g. MW, MF etc.)

Check that the body housing seal is in position and that the mating face with the base is clean and undamaged.

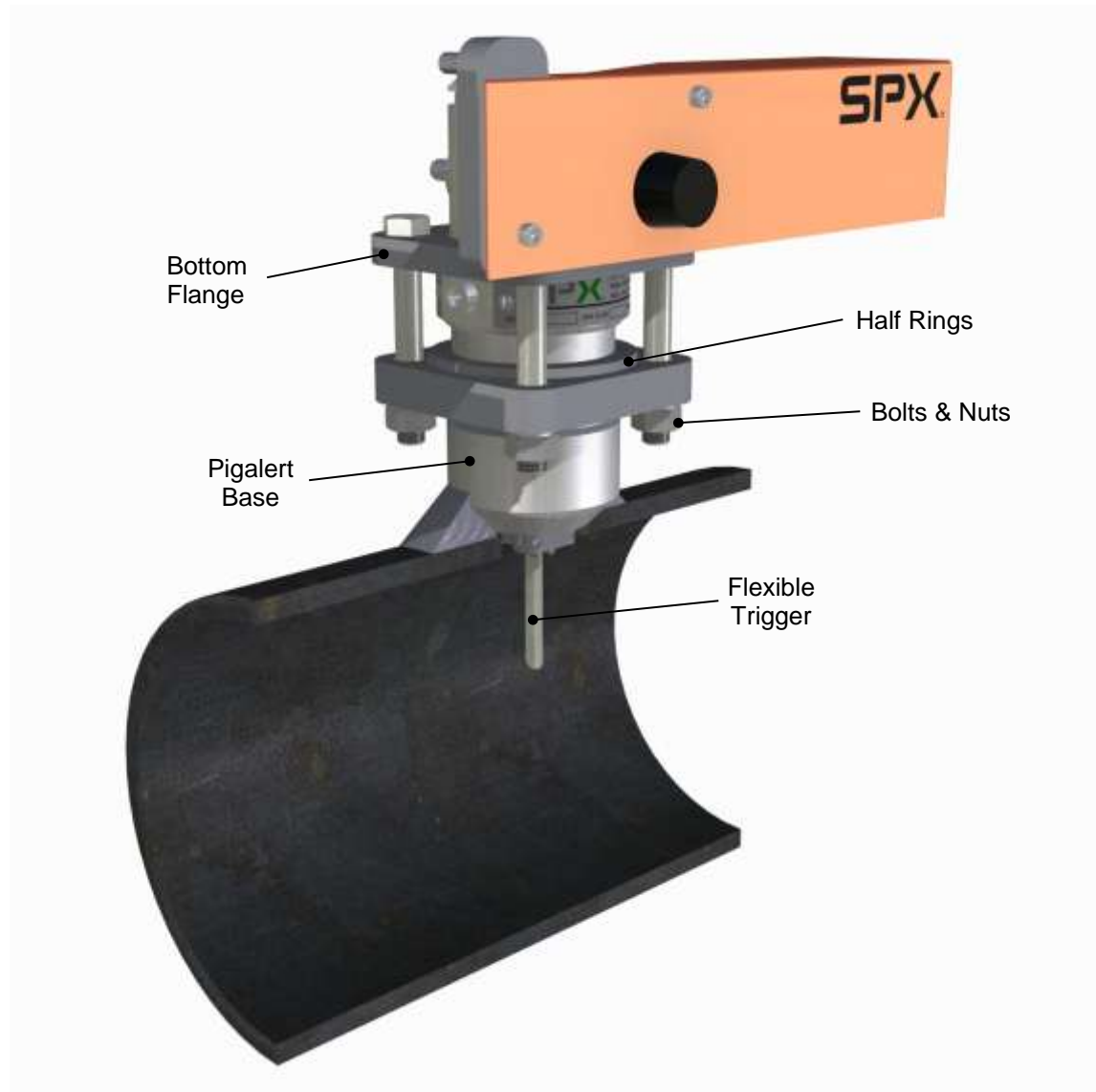

Place the bottom flange over the base with the large recess uppermost. Insert the body assembly into the base with the flexible trigger broadside to the flow direction, i.e. the operating cross shaft will be at right angles to the pipeline axis - **THIS IS IMPORTANT**

Locate the two half rings into the base groove, slide the bottom flange up to engage with the half rings.

Line up top and bottom flanges so that the sides are square to the operating shaft. Fit the securing bolts and nuts and tighten to 98Nm torque. These bolts are of high tensile material and must not be replaced by an inferior grade.

5.0 INSTALLATION - (CENTRE SECTION BALL VALVED MODELS)

Check that the valve seal is in position and that the mating face with the base is clean and undamaged.



Position the body assembly with the valve into the base and ensure that the flexible trigger is broadside to the flow direction, i.e. the operating cross shaft will be at right angles to the pipeline axis - **THIS IS IMPORTANT**

Fit the securing bolts and nuts and tighten to 80Nm torque. These bolts are high tensile material and must not be replaced by an inferior grade.

Once the securing bolts are fitted, they must not be removed when carrying out general servicing of the Pigalert.

The valve can only be serviced when the line pipe is depressurised.

6.0 INSTALLATION - (FLANGED BALL VALVED MODELS e.g. VMW, VMF)

Check that the valve seal is in position and that the mating face with the base is clean and undamaged.

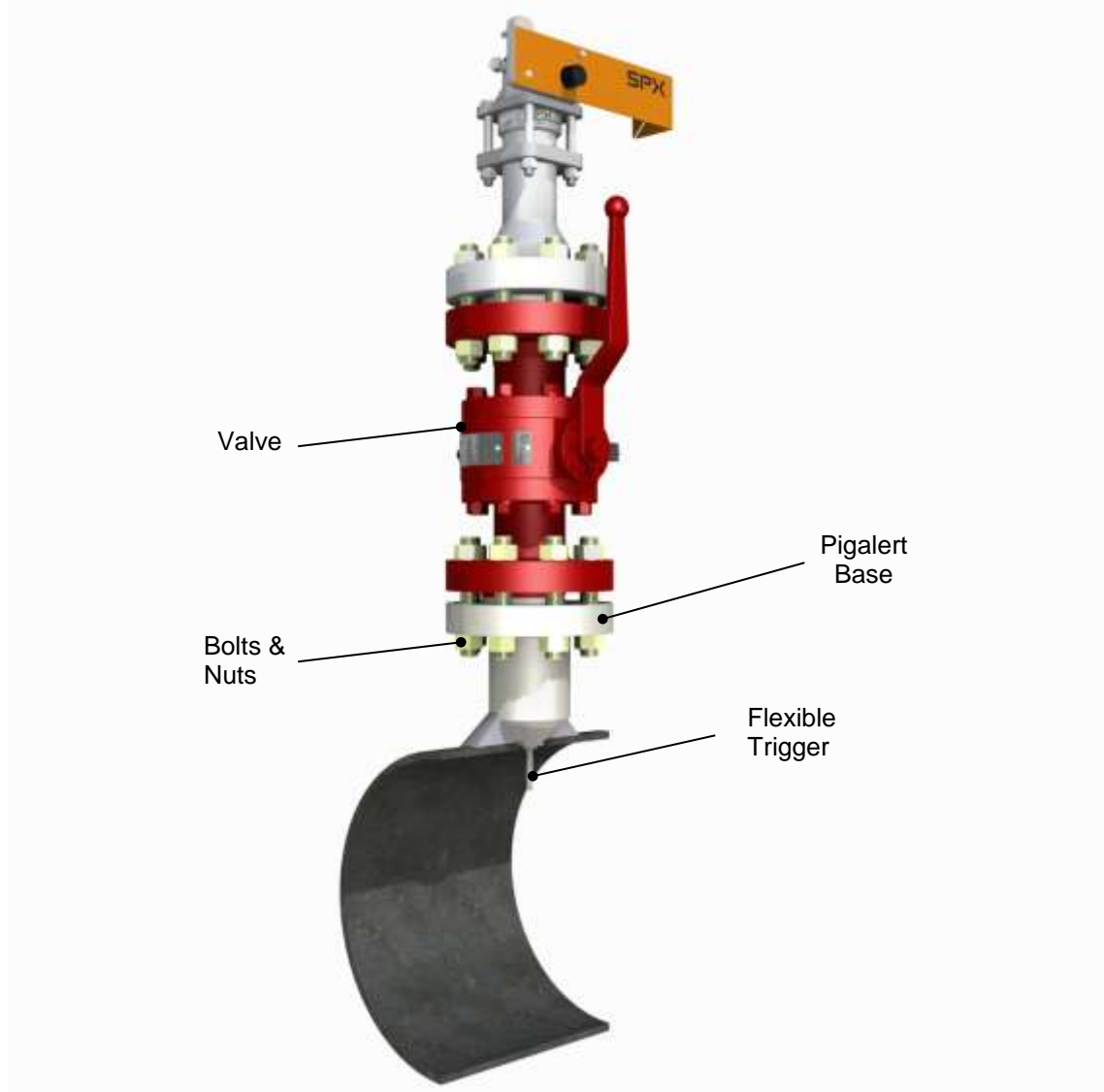

Position the body assembly with the valve into the base and ensure that the flexible trigger is broadside to the flow direction, i.e. the operating cross shaft will be at right angles to the pipeline axis - **THIS IS IMPORTANT**

Fit the securing bolts and nuts and tighten to 80Nm torque. These bolts are high tensile material and must not be replaced by an inferior grade.

Once these securing bolts are fitted, they must not be removed when carrying out general servicing of the Pigalert.

The valve can only be serviced when the line pipe is depressurised.

7.0 MAINTENANCE

UNDER PRESSURE REMOVAL/INSERTION (BALL VALVE MODEL ONLY):

THIS OPERATION MUST ONLY BE UNDERTAKEN BY COMPETENT PERSONNEL

Ensure that the Jacking Bracket is in a serviceable condition and that the ID number stamped on the top of the Pigalert Body matches the numbers stamped on the Jacking Bracket.

To carry out this requirement it is necessary to remove the attachments, i.e. flag and switch (refer to section 8.0).

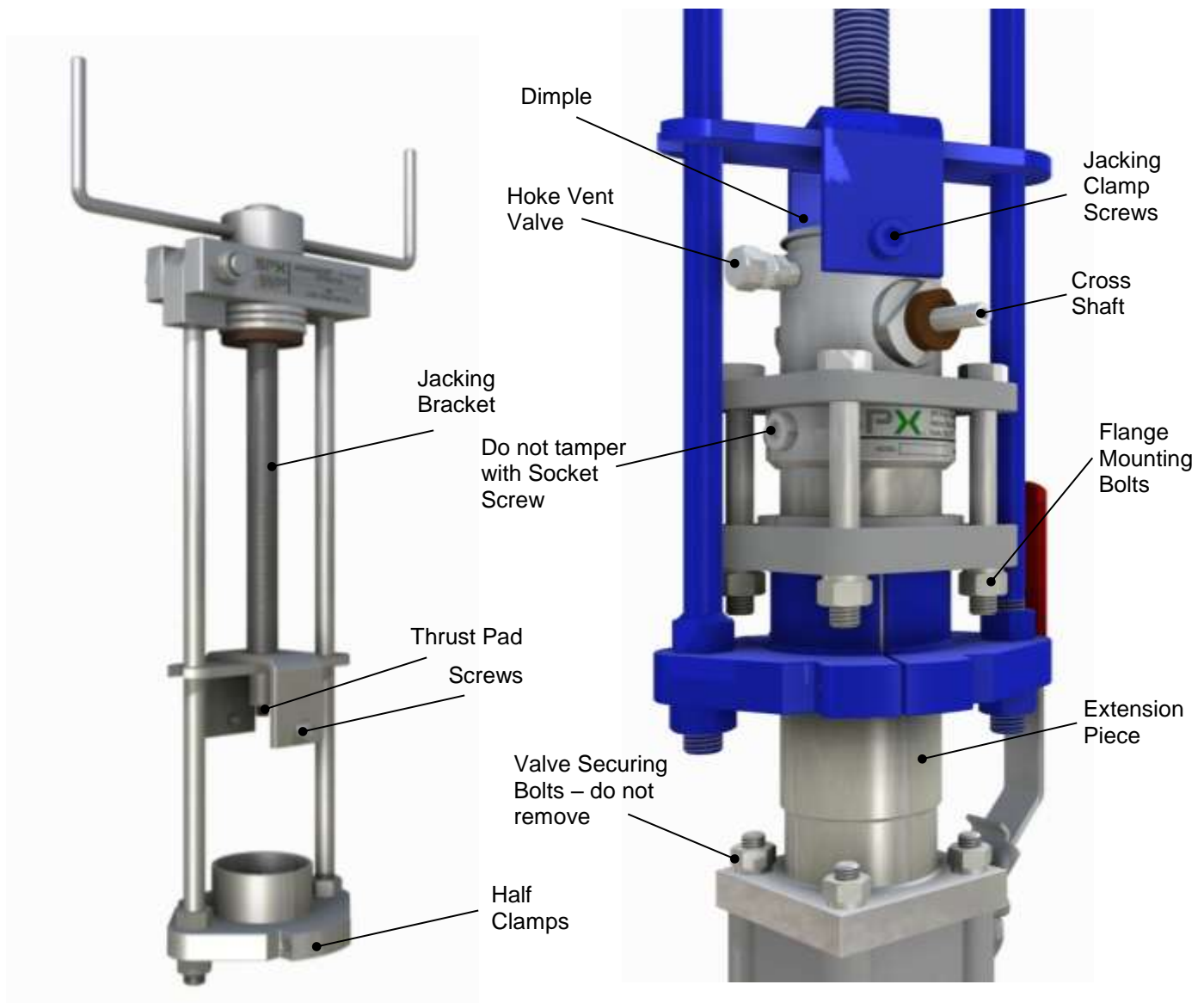

Using the jacking bracket, locate the two half clamps around the central extension piece of the Pigalert.

Adjust the screw length of the Jacking Bracket so that the thrust pad locates in the dimple on top of the Pigalert body whilst the upper part of the Jacking Bracket half clamps lie snugly in the Pigalert flange recess - No slackness should be apparent at this stage.

Ensure that the two screws on the jacking clamp are screwed into the groove on the upper Pigalert body. This ensures that the body will withdraw in low pressure situations. Release and remove the four flange mounting bolts.

If there is any leakage at this point the four flange bolts should be replaced and the Pigalert removed when the line is depressurised.

DO NOT touch the valve securing bolts. Carefully turn the hand wheel of the Jacking Bracket clockwise.

Any pressure contained within the system will force the body of the Pigalert upwards maintaining contact with the thrust pad, thus enabling the body section to be withdrawn under control.

The Jacking Bracket is designed to suit the required withdrawal length determined by the type of mounting and standout height of each Pigalert. It must not be used on any other units than that which it has been designed for.

When the screw has been fully withdrawn to its highest position, the valve can be closed. The fluid which is under pressure will be trapped in the upper section above the valve. This can be released by opening the Hoke vent valve at the top of the Pigalert body.

If the flow from the Hoke does not diminish and it is obvious that the Pigalert valve is passing, close the Hoke valve, open the Pigalert Valve and reinstall the Pigalert

DO NOT tamper with the socket screw located beneath the upper flange on the Pigalert; this is provided to purely anchor the body sleeve.

After venting; the Jacking Bracket can be removed and the body unit withdrawn manually for servicing. Cover the valve opening to prevent ingress of dirt.

For re-insertion reverse the foregoing procedure, make sure that the flexible trigger is broadside to the flow direction, i.e. the operating cross shaft will be at right angles to the pipeline axis – **THIS IS IMPORTANT.**

8.0 MAINTENANCE – GENERAL

FLAG REMOVAL

To remove the flag, remove the two 5mm cap head screws, release the 5mm socket cap screw, special washer and spring. Slide the flag unit off the spindle - store safely.

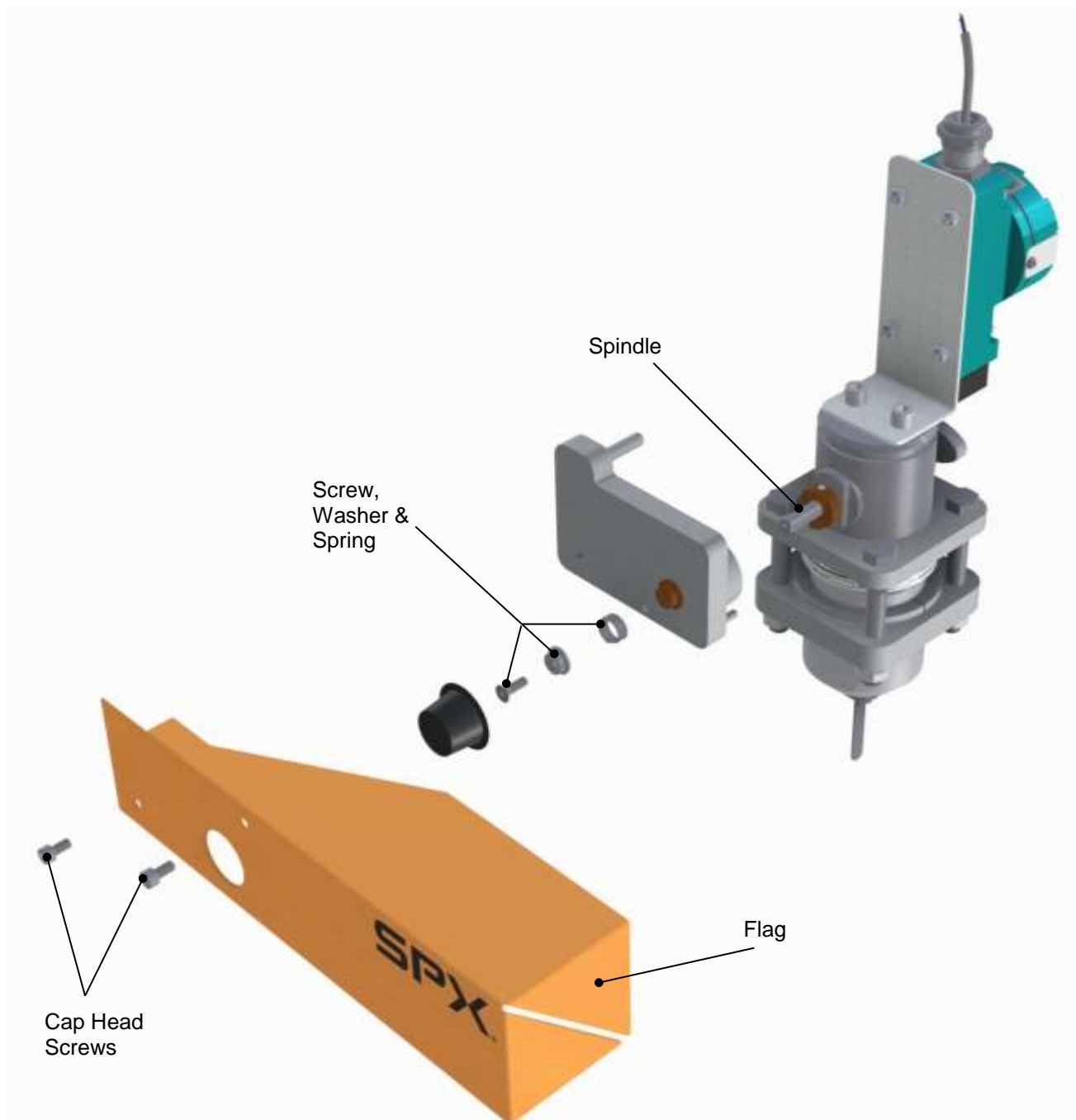

SWITCH REMOVAL

To remove switch, isolate supply as necessary, remove the two bracket clamp screws and store safely.

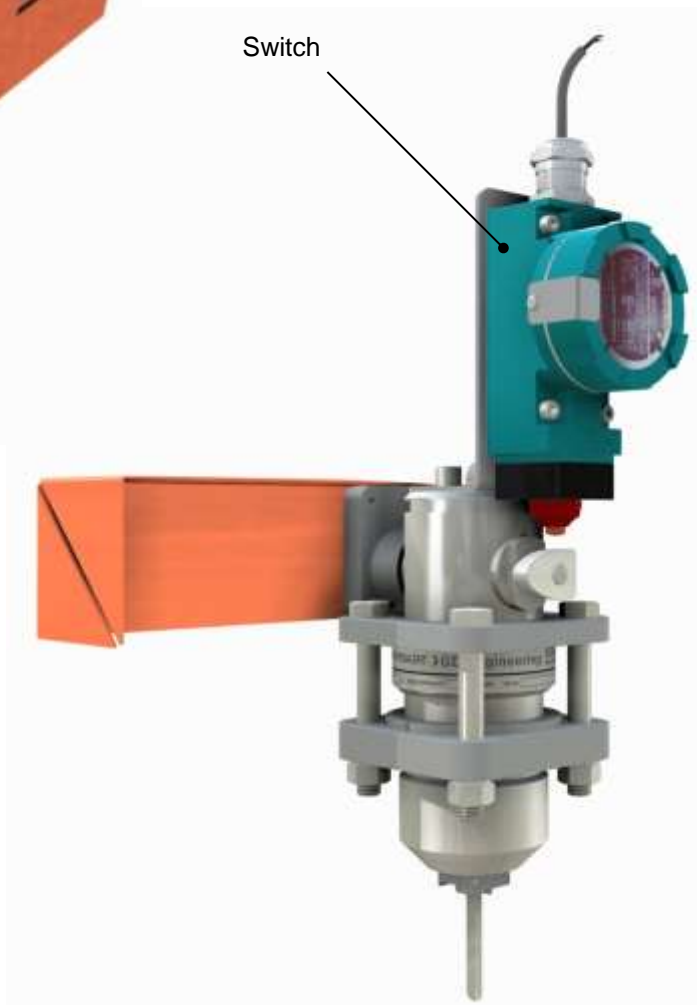
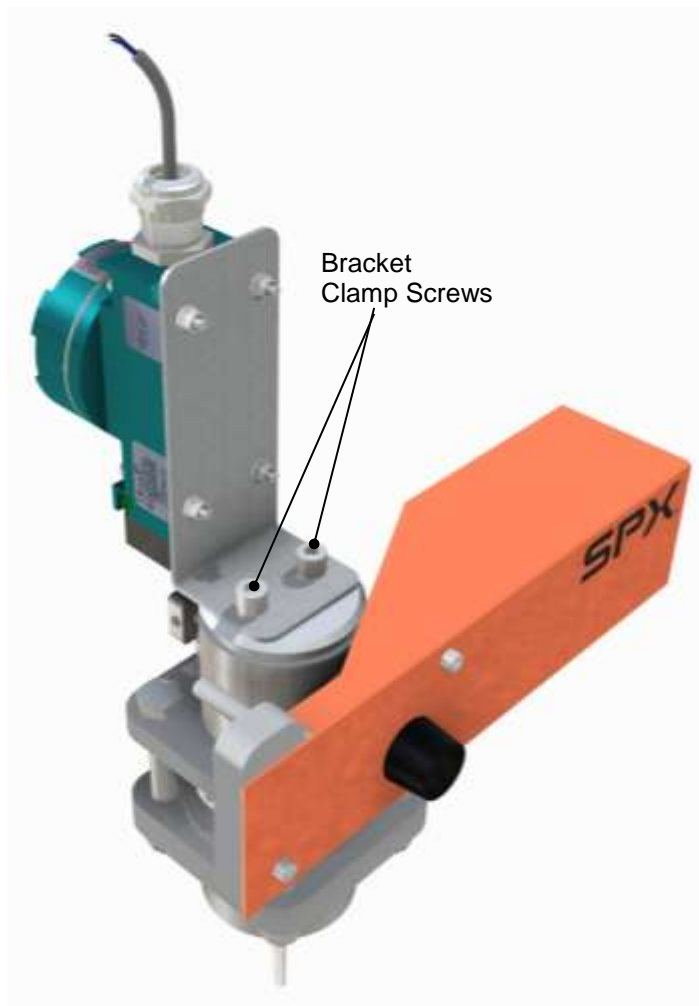

SPINDLE REPLACEMENT

DO NOT perform while the Pigalert is under pressure.

To remove and replace cross spindle seal/bushes, remove cam collar, unscrew the two stainless steel sealing plugs. Remove from the spindle. The spindle can now be withdrawn through the screwed opening adjacent to the long side of the spindle.

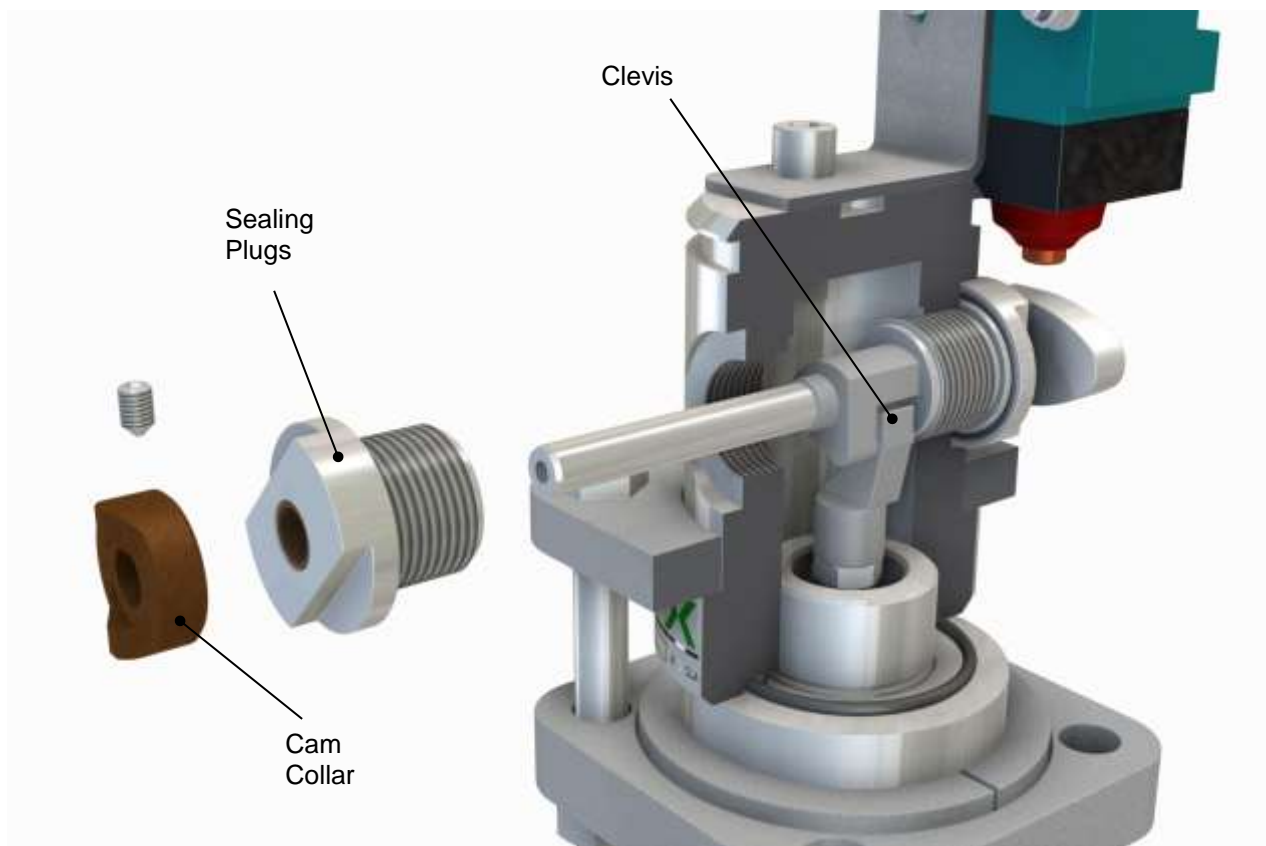

When replacing the spindle, ensure that the pin on the spindle correctly locates in the hole in the clevis.

Prior to re-fitting the sealing plus, replace the 'O' rings and the bonded seals.

TRIGGER REPLACEMENT

DO NOT perform while the Pigalert is under pressure.

To replace the trigger assembly, drive out the tension pins, and take care not to lose the rollers located on the pins. Remove the trigger assembly.

Re-assembly is a reversal of the above.

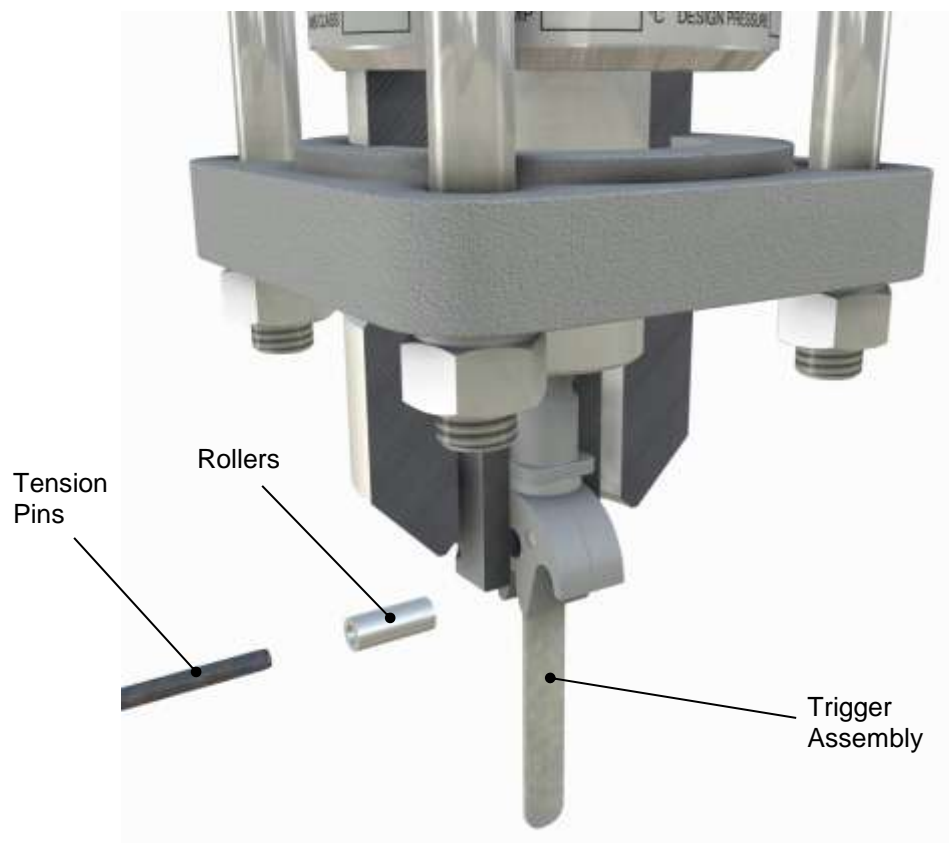

9.0 EXTENSION MODELS

These are supplied complete in set lengths of 1.0, 1.2, 1.4, 1.6, 1.8, 2.0 and 2.2 metres maximum.

The extension is formed by a tubular portion of the Pigalert sized to give the appropriate measurement, (from pipe wall to the extreme top of the Signaller).

All operations are as for the equivalent model of standard (non-extended) Pigalert.

10.0 SETTING DETAILS (ALL MODELS)

For correct flag operation, the tension pin in the flag weight should rest on the square flange by approximately 1mm. This can be adjusted by driving the tension pin in or out of the flag weight.

To check for correct operation, slightly pull the flag along the spindle - the flag should rotate to the upright position.

For Pigalerts fitted with an electrical micro-switch, the operating lever should be positioned to give 1mm clearance between the lever and the switch plunger in the non-operated position. To adjust, slacken the grub screw and rotate the lever to give the correct setting.

For Pigalerts fitted with a proximity switch, the actuation lever should be positioned to give a 2mm air gap between the lever and the switch.

11.0 MODELS WITH A COUNTER

If a counter is fitted, it may be reset to read zero by depressing and releasing the button on the counter unit. Due to the unit being fully sealed, maintenance cannot be carried out on the internal mechanism. The only maintenance required is a check to see that the counter is mounted and adjusted for correct operation.

Should it be necessary to contact GD Engineering with regard to any maintenance or operational issue, the unique signaller identification number, stamped on the top of the signaller body, should be referenced.

Hi-T Pigalert™

INSTALLATION, OPERATION AND MAINTENANCE MANUAL



SPX FLOW TECHNOLOGY

Retford Road, Worksop,
Nottinghamshire, S80 2PY
P: +44 (0) 1909 482323
F: +44 (0) 1909 477902
E: gd@spx.com

SPX reserves the right to incorporate our latest design and material changes without notice or obligation. Design features, materials of construction and dimensional data, as described in our bulletins, are provided for your information only and should not be relied upon unless confirmed in writing. Certified drawings are available upon request.

Based in Charlotte, North Carolina, SPX Corporation (NYSE: SPW) is a global Fortune 500 multi-industry manufacturing leader. For more information, please visit www.spx.com.

"The green ">" is a trademark of SPX Corporation, Inc."